

F720

IP65 Wash Zoom 18*40W rgbw 4-in-1 led

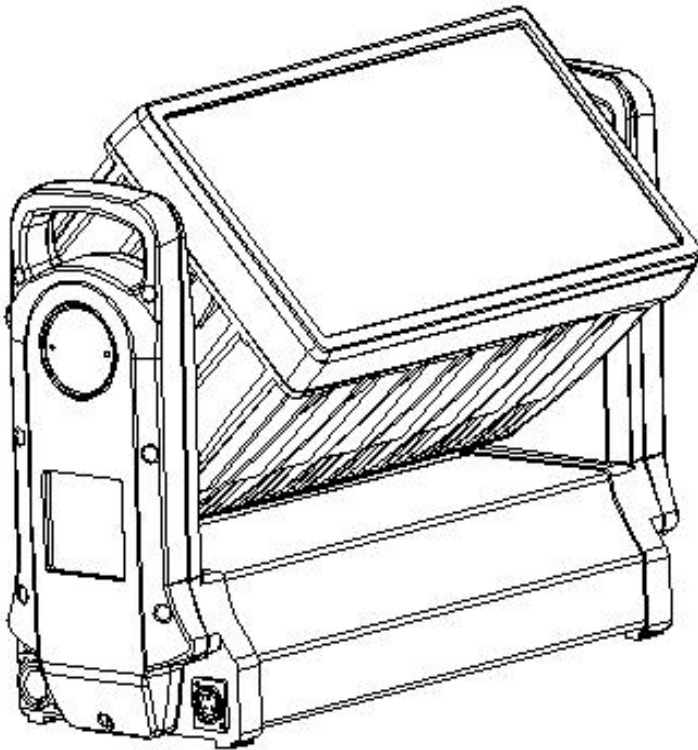

User manual

Please read the instructions carefully before us

TABLE OF CONTENTS

1. Safety Instructions	3-4
2. Technical Specifications.....	5-6
3.DMX Link.....	6-7
4.LUX Date.....	7
5.How To Control The Unit.....	8-10
6. DMX Channel List.....	10-24
7. Shape.....	25
8.Troube shooting.....	26
9. Fixture Cleaning.....	27

statement

The product has well capability and intact packing when leave factory. All of the user should comply with warning item and manual, any misuse cause of the damages are not included in our guarantee, and also can not be responsible for any malfunction & problem owing to ignore the manual.

1. Safety Instructions

Please keep this User Guide for future consultation. If you sell the unit to another user, be sure that they also receive this instruction booklet.

Unpack and check carefully there is no transportation damage before using the unit.

Before operating, ensure that the voltage and frequency of power supply match the power requirements of the unit.

It's important to ground the yellow/green conductor to earth in order to avoid electric shock.

The unit is for indoor use only. Use only in a dry location.

The unit must be installed in a location with adequate ventilation, at least 50cm from adjacent surfaces. Be sure that no ventilation slots are blocked.

Disconnect main power before replacement or servicing.

Make sure there are no flammable materials close to the unit while operating as it is fire hazard.

Use safety cable when fixes this unit. DO NOT handle the unit by taking its head only, but always by taking its base.

Maximum ambient temperature is T_a : 40°C. DO NOT operate it where the temperature is higher than this Unit surface temperature may reach up to 85°C. DO NOT touch the housing bare-hand during its operation. Turn off the power and allow about 15 minutes for the unit to cool down before replacing or serving.

the event of serious operating problem, stop using the unit immediately. Never

try to repair the unit by yourself. Repairs carried out by unskilled people can lead to damage or malfunction. Please contact the nearest authorized technical assistance center. Always use the same type spare parts.

⚠ DO NOT touch any wire during operation as high voltage might be causing electric shock.

Warning:

⚠ To prevent or reduce the risk of electrical shock or fire, do not expose the unit to rain or moisture.

⚠ DO NOT open the unit within five minutes after switching off.

⚠ The housing, the lenses, or the ultraviolet filter must be replaced if they are visibly damaged.

Caution:

There are no user serviceable parts inside the unit. DO NOT open the housing or attempt any repairs yourself. In the unlikely event your unit may require service, please contact your nearest dealer.

Installation:

The unit should be mounted via its screw holes on the bracket. Always ensure that the unit is firmly fixed to avoid vibration and slipping while operating. And make sure that the structure to which you are attaching the unit is secure and is able to support a weight of 10 times of the unit's weight. Also always use a safety cable that can hold 12 times of the weight of the unit when installing the fixture.

The equipment must be fixed by professionals. And it must be fixed at a place where is out of the touch of people.

2. Technical Specifications

Light Sources: 18*40W 4IN1 RGBW LED

Lamp life: \geq 50000 hours

Beam Angle:3.2° - 50°

Power Consumption: 720w

Power Voltage: AC 100-250V, 50/60Hz

Control

DMX Channel:19/25/61CH

Control Modes: DMX512

Pan/Tilt

Pan : / , Tilt : 270°

Display

Size (L*W): 46*34 (1.5 inches)

4 touch buttons,Color led screen with 180 degree rotation

Switch between Chinese and English

Base hanger: 2pcs Quick lock light hook

Construction

Display:180° reversible LCD Display

Data In/Out socket: 3-pin XLR sockets

Power Socket: Waterproof Powercon in/out

Environment temperature: -10°C--- +40°C

Protection Rating: IP65

Product software version number : V1.0

Features

Electronic control technology: Menu or console control lamp reset; 0-100% dimming; constant current drive mode; temperature sensing detection, intelligent adjustment of light source power; lamp information query; intelligent fan speed control

- Effect configuration: full range dimming, 65536 levels of dimming accuracy; fast strobe 1~25Hz; preset multiple color macro functions; preset multiple effect macro functions;
- Working temperature: $-10^{\circ}\text{C} \sim 45^{\circ}\text{C}$
- Safety protection: over current, over voltage, over heat protection, XY fixed lock
- Protection index: IP65
- Maximum number of connections: 220V: less than 6 units, 2.5 square meters of wires are required
120V: within 3 units, 2.5 square meters of wires are required

Product Size:508*208*351 MM

N. W : 16 KGS

3. DMX Link

Accessories

- Signal line: 3-pin 1 piece
- Power cord: 1 piece
- Chinese/English manual: 1 piece



Figure 1

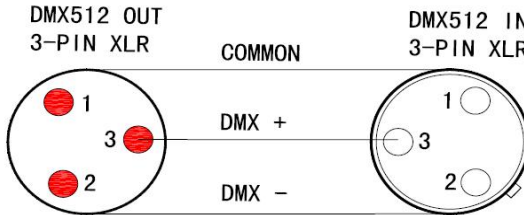
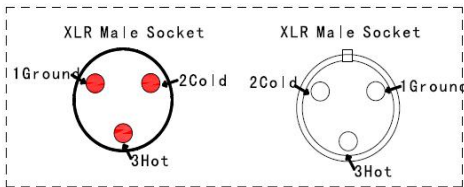

Figure 2



XLR Pin Configuration
pin1=Ground
pin2=Data Compliment (negative)
pin3=Data true (positive)

Pin1: ground pin2: negative pin3: positive

DMX connection: In order to ensure the best transmission of DMX data, try to choose the shortest connection path during the lamp connection process. The order in which the lamps are connected via DMX will not affect the DMX address code. For example, the address code of a fixture is set to 1, no matter where the fixture is connected to any location, its address code will not be changed. This is due to the principle of the DMX controller.

Operation mode: You can operate in the following three modes:

- Self-propelled mode-the lamp can automatically complete all color changes
- DMX control mode-each lamp can be individually controlled by a standard DMX512 console

•Master-slave mode-any lamp can work as a master in any of the previous modes, and other lamps will work as slaves synchronously

4. LUX Data

Beam Angle =3.2°

R lux	25300	15600	8080	3140
G lux	38500	25500	13000	5180
B lux	11100	6950	3460	1390
W lux	46800	35400	17600	7080
4in1 lux	119000	78500	39900	15700

Beam Angle =50°

R lux	7260	988	368	156
G lux	12600	1650	620	246
B lux	3480	449	170	67
W lux	16500	2110	812	322
4in1 lux	36600	4860	1880	751

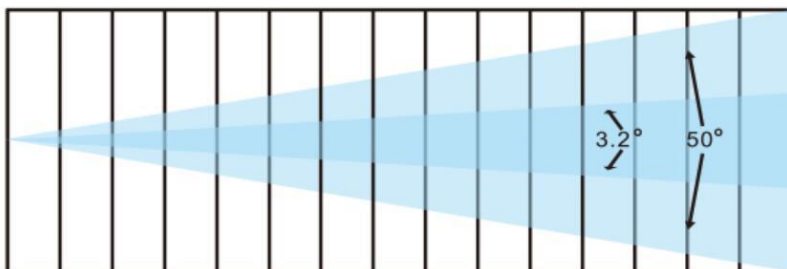

Spot diameter (cm) 22x40cm 36x56cm 55x70cm 99x88cm

5. Display & Menu

Display:

MENU	To select the programming functions
DOWN	To go backward in the selected functions
UP	To go forward in the selected functions
ENTER	To confirm the selected functions

Set DMX Address Code

- 1 Press **"Menu"** to "Set DMX Address",and press**"ENTER"** keys to enter into
- 2 Show "Set DMX Address DMX Address:**001**",Press the **"UP and DOWN"** keys to amended
- 3 Press **"ENTER"**keys to save and Exit,Press the**"MENU"**Keys does not save and Exit

1-MENU 2-UP 3-DOWN 4-ENTER			
Menu	1.Mic Sense	001 - 100	Sound sensitivity adjustment
	2.Language	English	Chinese
	3.No Signal	1.Black Out 2.Hold	
	4.Fan Set	1. Automatic (Auto) 2. Low speed 3. High speed	
	5.Reset	1.YES	
		2. NO	
6. Default	1.YES		
	3. NO		
Menu	7.Adjust	Pass Word: up+down+up+down	
		Tilt	Changing the value of Tilt/Focus can correct the angle; changing the value of R/G/B/W can adjust the white balance
		Focus	
		Red	
		Green	
		Blue	
White			

Address	Setting from 001 - 512		
Reverse	reversed setting	Tilt	1.Yes
			2.No
		Display	1.Yes
			2.No
Information	1.CH Value		Each channel show CH value
	2.Temp ____°C		Show the temperature of led board
	3.Soft V1.0		Show the version number
Channel	19 channels		
	25 channels		
	61 channels		
Mode	DMX 512		
	AUTO		
	SOUND		
	Manual		
Menu	1. Master/ 2.Alone	1.Tilt (Y axis): 0--255	
		2.Focus:0--255	
		3.Red: 0--255	
		4.Greed: 0--255	
		5.Blue: 0--255	
		6.White: 0--255	
			Set control mode

	7.Strobe: 0-255	
--	-----------------	--

6.DMX Channel List

Model 1 - CH19

Channel	Function	Display	Value
CH-1	Red dimming	Red	0 --- 255
CH-2	Red trim	Red trim	0 --- 255
CH-3	Green dimming	Green	0 --- 255
CH-4	Green trim	Green trim	0 --- 255
CH-5	Blue dimming	Blue	0 --- 255
CH-6	Blue trim	Blue trim	0 --- 255
CH-7	White dimming	White	0 --- 255
CH-8	White trim	White trim	0 --- 255
		NO	0--15
		R100%,G UP,B0%	16--35
		R DOWM,G100%,B0%	36--55
		R0%,G100%,B UP	56--75

CH-9	Color temperature	R0%,G DOWM,B100%	76--95
		R UP,G0%,B100%	96--115
		R100%,G0%,B DOWM	116--135
		R100%,G UP,B UP	136--155
		R DOWM,G DOWM,B100%	156--175
		R100%,G100%,B100%,W 100%	176--195
		2800K	196--200
		3200K	201--205
		3500K	206--210
		4000K	211--215
		4500K	216--220
		5000K	221--225
		5500K	226--230
		6000K	231--235
CH-9	Color temperature	6500K	236--240
		7000K	241--245
		7500K	246--250

		8000K	251--255
CH-10	Macro color	NO effects	0--9
		Macro color 1	10--19
		Macro color 2	20--29
	(10 number one type)
		Macro color 24	240--249
		Macro color 25	250--255
CH-11	Total dimming	from dark to bright	0--255
CH-12	Dimming	Dimming fine-tuning control	0--255
CH-13	Strobe	Light up	0--3
		Synchronous strobe speed from slow to fast (1HZ-25HZ)	4--203
		Random strobe	204--255
CH-14	Pan	Pan control	0--255
CH-15	Pan fine-tuning	Pan fine-tuning control	0--255
CH-16	Pan speed	From fast to slow	0--255
CH-17	Zoom	Zoom	0--255
		Model 1	0--49

CH-18	Dimming mode	Model 2	50--99
		Model 3	100--149
		Model 4	150--255
CH-19	Reset	No effects	0--250
		Reset within 5S	251--255

Model 2 - CH25

Channel	Function	Display	Value
CH-1	Pan	Pan control	0--255
CH-2	Pan fine-tuning	Pan fine-tuning control	0--255
CH-3	Pan speed	From fast to slow	0--255
CH-4	Zoom	Zoom	0--255
CH-5	Total dimming	from dark to bright	0--255
CH-6	Strobe	Light up	0--3
CH-6	Strobe	Synchronous strobe speed from slow to fast (1HZ-25HZ)	4--203
		Random strobe	204--255
CH-7	Red dimming	Linear dimming from	
CH-8	Green dimming		0 --- 255

CH-9	Blue dimming	dark to bright	0 --- 255
CH-10	White dimming		0 --- 255
CH-11	Color temperature	NO	0--15
		R100%,G UP,B0%	16--35
		R DOWM,G100%,B0%	36--55
		R0%,G100%,B UP	56--75
		R0%,G DOWM,B100%	76--95
		R UP,G0%,B100%	96--115
		R100%,G0%,B DOWM	116--135
		R100%,G UP,B UP	136--155
		R DOWM,G DOWM,B100%	156--175
		R100%,G100%,B100%,W 100%	176--195
		2800K	196--200
		3200K	201--205
		3500K	206--210
4000K	211--215		

CH-11	Color temperature	4500K	216--220
		5000K	221--225
		5500K	226--230
		6000K	231--235
		6500K	236--240
		7000K	241--245
		7500K	246--250
		8000K	251--255
CH-12	Macro color	NO effects	0--9
		Macro color 1	10--19
		Macro color 2	20--29
	(10 number one type)
CH-12	Macro color	Macro color 24	240--249
		Macro color 25	250--255
		NO effects	0--7
		Monochrome pattern 1	8--15
		Monochrome pattern 2	16--23
	(8 number one type)

CH-13	Static pattern	Monochrome pattern 15	120--135
		Mixed color pattern 1	136--143
		Mixed color pattern 2	144--151
	(8 number one type)
		Mixed color pattern 11	216--223
		Mixed color pattern 12	224--255
CH-14	Dynamic pattern	NO effect	0--9
		Monochrome dynamic pattern 1	10--14
		Monochrome dynamic pattern 2	15--19
	(5 number one type)
		Monochrome dynamic pattern 23	120--124
		Mixed color dynamic pattern 1	125--129
CH-14	Dynamic pattern	Mixed color dynamic pattern 2	130--134
	(5 number one

			type)
		Mixed color dynamic pattern 12	180--184
		Mixed color dynamic pattern 13	185--255
CH-15	Pattern translation (with 14 channels)	Select dynamic pattern scene	0--255
CH-16	Dynamic pattern speed (with 14 channels)	No effect	0--9
		Forward, from fast to slow	10--132
		Go backward, from slow to fast	133--255
CH-17	Pattern effect fade	Pattern effect fade	0--255
CH-18	Background total dimming	Background 0-100% dimming	0--255
CH-19	Background strobe	Background strobe	0--255
CH-20	Background color Red	Linear dimming from dark to bright	0--255
CH-21	Background color Green	Linear dimming from dark to bright	0--255
CH-22	Background color Blue	Linear dimming from dark to bright	0--255

CH-23	Background color White	Linear dimming from dark to bright	0--255
CH-24	Dimming mode	Model 1	0--49
		Model 2	50--99
		Model 3	100--149
		Model 4	150--255
CH-25	Reset	No effects	0--250
		Reset within 5S	251--255

Model 3 - CH61

Channel	Function	Display	Value
CH-1	Pan	Pan control	0--255
CH-2	Pan fine-tuning	Pan fine-tuning control	0--255
CH-3	Pan speed	From fast to slow	0--255
CH-4	Zoom	Zoom	0--255
CH-5	Total dimming	from dark to bright	0--255
CH-6	Strobe	Light up	0--3
		Synchronous strobe speed from slow to fast (1HZ-25HZ)	4--203

		Random strobe	204--255
CH-7	Red dimming	Linear dimming from dark to bright	
CH-8	Green dimming		0 --- 255
CH-9	Blue dimming		0 --- 255
CH-10	White dimming		0 --- 255
CH-11	Color temperature	NO	0--15
		R100%,G UP,B0%	16--35
		R DOWM,G100%,B0%	36--55
		R0%,G100%,B UP	56--75
		R0%,G DOWM,B100%	76--95
		R UP,G0%,B100%	96--115
		R100%,G0%,B DOWM	116--135
		R100%,G UP,B UP	136--155
		R DOWM,G DOWM,B100%	156--175
CH-11	Color temperature	R100%,G100%,B100%,W 100%	176--195
		2800K	196--200

		3200K	201--205
		3500K	206--210
		4000K	211--215
		4500K	216--220
		5000K	221--225
		5500K	226--230
		6000K	231--235
		6500K	236--240
		7000K	241--245
		7500K	246--250
		8000K	251--255
CH-12	Macro color	NO effects	0--9
		Macro color 1	10--19
		Macro color 2	20--29
CH-12	Macro color(10 number one type)
		Macro color 24	240--249
		Macro color 25	250--255
		NO effects	0--7
		Monochrome pattern 1	8--15

CH-13	Static pattern	Monochrome pattern 2	16--23
	(8 number one type)
		Monochrome pattern 15	120--135
		Mixed color pattern 1	136--143
		Mixed color pattern 2	144--151
	(8 number one type)
		Mixed color pattern 11	216--223
		Mixed color pattern 12	224--255
		NO effect	0--9
		Monochrome dynamic pattern 1	10--14
		Monochrome dynamic pattern 2	15--19
	(5 number one type)
		Monochrome dynamic pattern 23	120--124
		Mixed color dynamic pattern 1	125--129

CH-14	Dynamic pattern	Mixed color dynamic pattern 2	130--134
	(5 number one type)
		Mixed color dynamic pattern 12	180--184
		Mixed color dynamic pattern 13	185--255
CH-15	Pattern translation (with 14 channels)	Select dynamic pattern scene	0--255
CH-16	Dynamic pattern speed (with 14 channels)	No effect	0--9
		Forward, from fast to slow	10--132
		Go backward, from slow to fast	133--255
CH-17	Pattern effect fade	Pattern effect fade	0--255
CH-18	Background total dimming	Background 0-100% dimming	0--255
CH-19	Background strobe	Background strobe	0--255
CH-20	Background color Red	Linear dimming from dark to bright	0--255
CH-21	Background color	Linear dimming from	0--255

	Green	dark to bright	
CH-22	Background color Blue	Linear dimming from dark to bright	0--255
CH-23	Background color White	Linear dimming from dark to bright	0--255
CH-24	Dimming mode	Model 1	0--49
		Model 2	50--99
		Model 3	100--149
		Model 4	150--255
CH-25	Reset	No effects	0--250
		Reset within 5S	251--255
CH-26	Area 1 red	Zone 1 red dimming	0--255
CH-27	Area 1 green	Zone 1 green dimming	0--255
CH-28	Area 1 blue	Zone 1 blue dimming	0--255
CH-29	Area 1 white	Zone 1 white dimming	0--255
.....
CH-58	Area 9 red	Zone 9 red dimming	0--255
CH-59	Area 9 green	Zone 9 green dimming	0--255
CH-60	Area 9 blue	Zone 9 blue dimming	0--255
CH-61	Area 9 white	Zone 9 white dimming	0--255

7. Shape

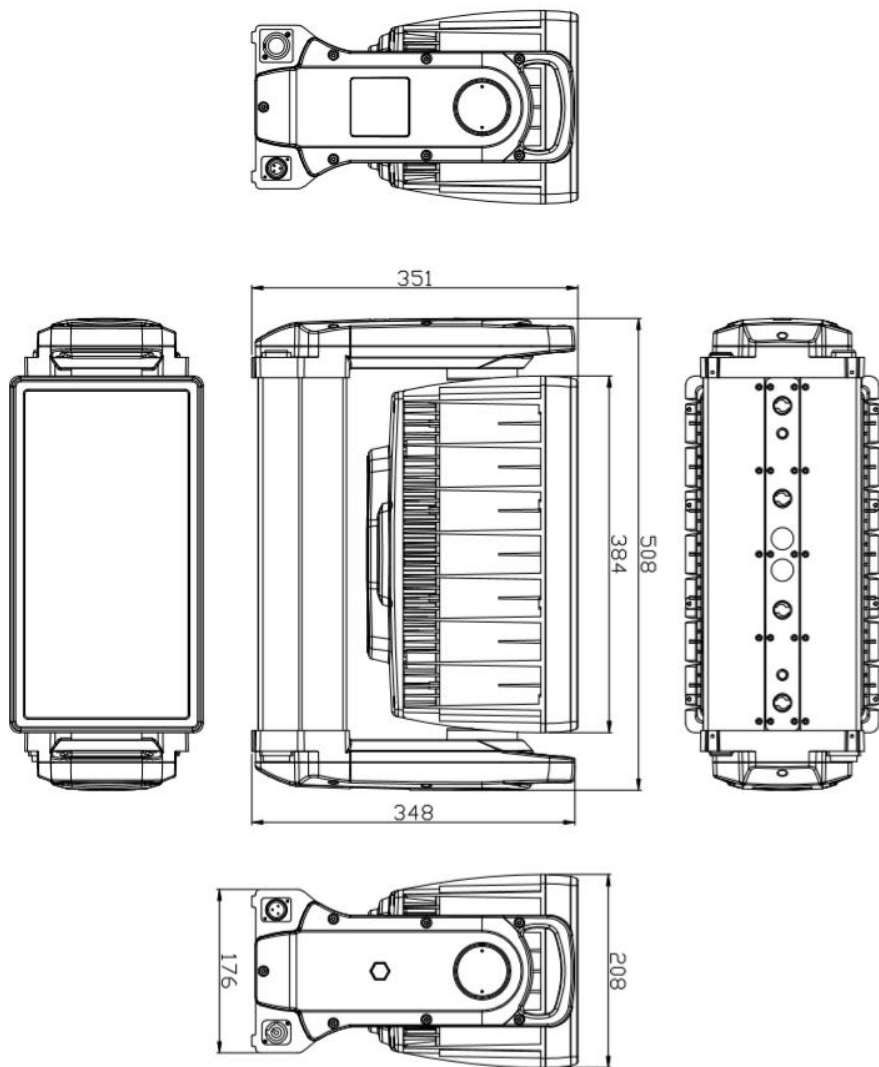

8. Trouble shooting

Following are a few common problems that may occur during operation. Here are some suggestions for easy troubleshooting:

A. The unit does not work, no light and the fan does not work

1. Check the connection of power and main fuse.
2. Measure the mains voltage on the main connector.
3. Check the power on LED.

B. Not responding to DMX controller

1. DMX LED should be on. If not, check DMX connectors, cables to see if link properly.
2. If the DMX LED is on and no response to the channel, check the address settings and DMX polarity.
3. If you have intermittent DMX signal problems, check the pins on connectors or on PCB of the unit or the previous one.
4. Try to use another DMX controller.
5. Check if the DMX cables run near or run alongside to high voltage cables that may cause damage or interference to DMX interface circuit.

C. One of the channels is not working well

1. The stepper motor might be damaged or the cable connected to the PCB is broken.
2. The motor's drive IC on the PCB might be out of condition.

9. Fixture Cleaning

The cleaning of internal and external optical lenses and/or mirrors must be carried out periodically to optimize light output. Cleaning frequency depends on the environment in which the fixture operates: damp, smoky or particularly dirty surrounding can cause greater accumulation of dirt on the unit's optics.

- **Clean with soft cloth using normal glass cleaning fluid.**
- **Always dry the parts carefully.**
- **Clean the external optics at least every 20 days. Clean the internal optics at least every 30/60 days.**